

## CBP-3 Back Pressure Control Regulators Diaphragm/Seat Replacement Instructions

**Make sure you thoroughly understand these directions before proceeding  
MAKE SURE THE REGULATOR IS DISCONNECTED FROM AIR SOURCE  
MAKE SURE ANY RESIDUAL PRESSURE IS BLEED OFF FROM REGULATOR.**

### Instructions

1. Completely read these instructions before performing any of the operations.
2. Make sure the regulator is disconnected from pressure source; make sure any residual pressure is bled off from the regulator. **FAILURE TO DO THIS WILL RESULT IN SERIOUS PERSONAL INJURY. DO NOT PROCEED UNTIL PRESSURE HAS BEEN REMOVED AND/OR TERMINATED**
23. Securely clamp the regulator over the flats in a vise.
24. Turn the knob counterclockwise as far as it will go. This should allow enough room for a standard adjustable end wrench to fit on the flats of the cap. Otherwise you will have to loosen the set screw on the knob using a 3/32 Allen wrench and remove the knob.
25. Remove the cap and adjusting screw as a unit. The range spring will be securely held inside the cap if this unit is equipped with a spring stabilizer. Earlier models do not have a stabilizer, in which case the range spring will be sitting on top of the diaphragm.
26. Remove the PTFE slip washer.
27. Remove the diaphragm assembly.
28. Remove the large Viton O-ring in the cavity.
29. Remove the seat.
30. Thoroughly blow out the inside of regulator body using clean, dry compressed air.
31. Clean sealing surface with a cotton swab moistened with isopropyl alcohol.
32. Place new lower flat seal in the seat.
33. Place the seat in the body and start the threads by hand. Tighten the seat hand tight.
34. Finish tightening seat retainer to 25 lbf·ft (34 N·m).
35. Coat the new o-ring with a suitable lubricant, such as Krytox, and place it in the groove inside the cavity.
36. Place new diaphragm assembly onto regulator cavity.
37. Place range spring and spring button onto diaphragm assembly unless it was equipped with a stabilizer and is inside the cap.
38. Place a small amount of Krytox or other lubricant on the outer threads of the body if the regulator body is steel. Do not apply lubricant to threads if regulator body is brass.
39. Put the cap over the regulator and engage threads by hand. Tighten hand tight.

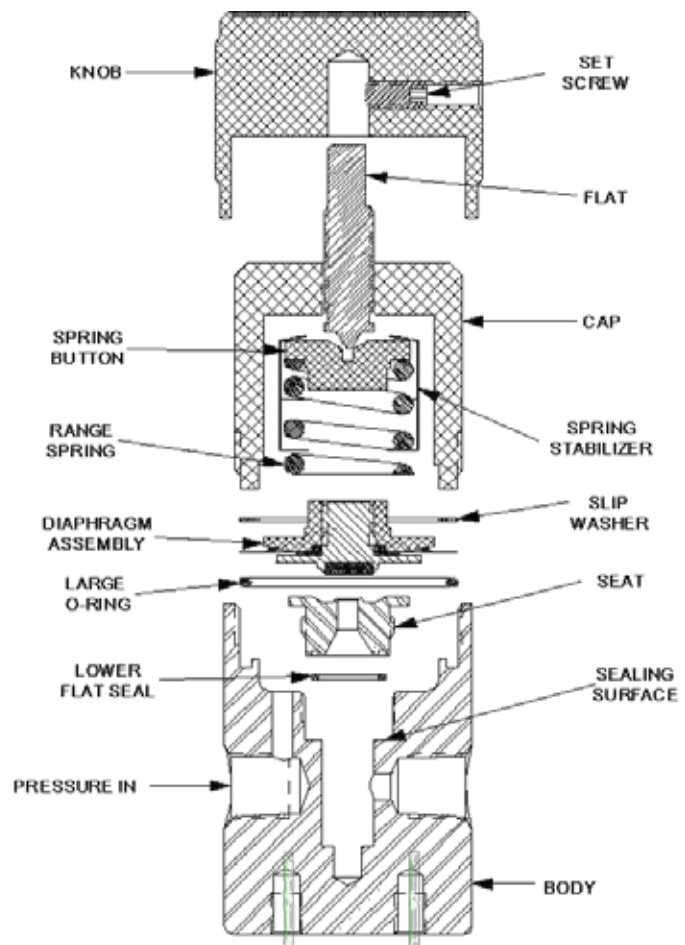

40. Finish tightening cap to 40 lbf·ft (54 N·m).
41. Attach a pressure gauge and source of pressure to the inlet port.
42. Squirt a leak detecting fluid around the base of the cap where it meets the body. Agitate the fluid to form foam and apply around the 0.125 (3.1mm) leak detection port in the bonnet of the cap.
43. Slowly turn the knob clockwise while applying inlet pressure. As you apply more pressure to the inlet, gas will escape from the outlet. Turning the knob more turns clockwise will stop the gas escaping from the outlet.
44. Continue applying inlet pressure and turning the knob until a back pressure equal to 110% of the maximum rating for this regulator has been attained. Reapply the leak detecting fluid as needed.
45. Let stand for 2 minutes. If no leaks are noticed, you may proceed to the next step.
46. Relieve the source of pressure while backing off on the adjusting knob. Continue backing off on adjustment knob until it is all the way out and will turn no further.
47. The regulator is now ready for service.

---

## ***GO Regulator***

405 Centura Court • PO Box 4866 • Spartanburg, SC 29303

Phone (864) 574-7966 • Fax (864) 574-5608

[www.goreg.com](http://www.goreg.com) • [sales-go@circor.com](mailto:sales-go@circor.com)