

SBPR Back Pressure Control Regulators Diaphragm/Seat Replacement Instructions

**Make sure you thoroughly understand these directions before proceeding
MAKE SURE THE REGULATOR IS DISCONNECTED FROM AIR SOURCE
MAKE SURE ANY RESIDUAL PRESSURE IS BLED OFF FROM REGULATOR.**

Instructions

1. Completely read these instructions before performing any of the operations.
2. Make sure the regulator is disconnected from pressure source; make sure any residual pressure is bled off from the regulator. **FAILURE TO DO THIS WILL RESULT IN SERIOUS PERSONAL INJURY. DO NOT PROCEED UNTIL PRESSURE HAS BEEN REMOVED AND/OR TERMINATED**
3. Securely clamp the regulator over the flats in a vise.
4. Turn the knob counterclockwise as far as it will go. This should allow enough room for a standard adjustable end wrench to fit on the flats of the cap. Otherwise you will have to remove the pry-out plug from top of knob, remove knob nut and unscrew knob from adjusting screw.
5. Remove the cap and adjusting screw as a unit. The range spring will be securely held inside the cap if this unit is equipped with a spring stabilizer. Earlier models do not have a stabilizer, in which case the range spring will be sitting on top of the diaphragm.
6. Remove the foam damper and diaphragm, unless the diaphragm assembly remained in the cap. If the diaphragm assembly remained in the cap you will have to rotate the adjusting screw clockwise to force it out. Gently rock the diaphragm assembly back and forth while turning the adjusting screw. This will facilitate the removal of the diaphragm assembly.
7. Remove the large vacuum resist spring.
8. Using a 1 1/8" socket, loosen and remove the sub-seat.
9. Carefully remove the old O-ring.
10. Thoroughly blow out the inside of regulator body using clean, dry compressed air.
11. Clamp sub-seat in a vise over the 1 1/8 hex.
12. Using a 5/8" socket, remove the seat from the sub-seat.
13. Clean seat surface with a cotton swab moistened with isopropyl alcohol.
14. Install new lower flat seal into groove of new seat.
15. Place the seat in the sub-seat and start the threads by hand. Tighten the seat hand tight.
16. Finish tightening seat to 25 lbf·ft (34 N·m).
17. Carefully work new O-ring over the threads of the sub-seat.
18. Start the threads of the sub-seat in the body by hand. Continue tightening until finger tight.

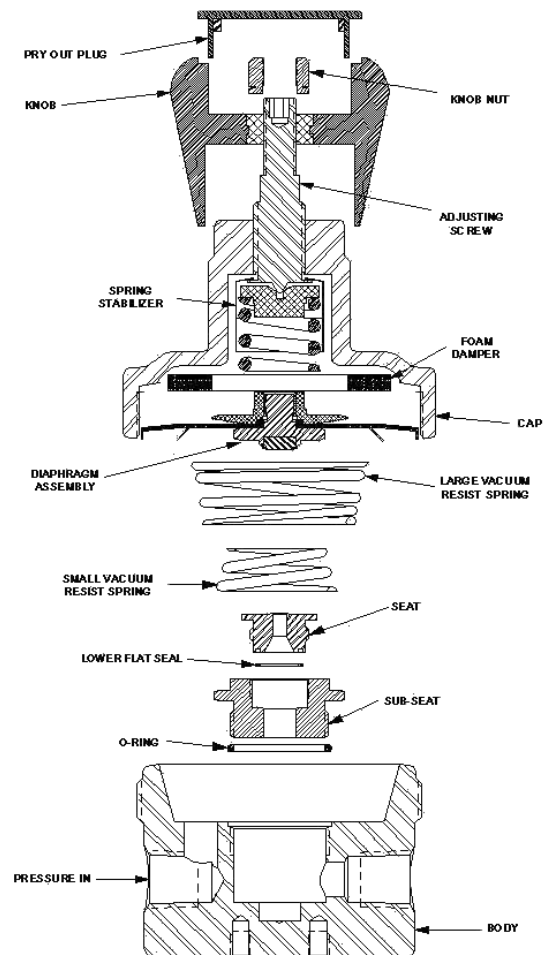

19. Finish tightening seat to 25 lbf•ft (34 N•m). (15 lbf•ft (20 N•m) for brass body).
20. Place the large and small vacuum resist springs in the cavity of the regulator. Note the orientation of the springs.
21. Place diaphragm assembly and foam damper onto regulator cavity
22. Place range spring and spring button onto diaphragm assembly unless it was equipped with a stabilizer and is inside the cap.
23. Place a small amount of Krytox or other lubricant on the outer threads of the body if the regulator body is steel. Do not apply lubricant to threads if regulator body is brass.
24. Put the cap over the regulator and engage threads by hand. Tighten hand tight.
25. Finish tightening cap to 60 lbf•ft (81 N•m). (40 lbf•ft (54 N•m) with PTFE/ viton diaphragm).
26. Attach a pressure gauge and source of pressure to the inlet port.
27. Squirt a leak detecting fluid around the base of the cap where it meets the body. Agitate the fluid to form foam and apply around the 0.125 (3.1mm) leak detection port in the bonnet of the cap.
28. Slowly turn the knob clockwise while applying inlet pressure. As you apply more pressure to the inlet, gas will escape from the outlet. Turning the knob more turns clockwise will stop the gas escaping from the outlet.
29. Continue applying inlet pressure and turning the knob until a back pressure equal to 110% of the maximum rating for this regulator has been attained. Reapply the leak detecting fluid as needed.
30. Let stand for 2 minutes. If no leaks are noticed, you may proceed to the next step.

If knob was removed:

- Spin the knob as far down as it will go on the adjusting screw.
 - Tighten the knob nut against the metal insert, being careful not to change the position of the knob while doing this.
 - Install pry-out plug into top of knob.
23. Relieve the source of pressure while backing off on the adjusting knob. Continue backing off on adjustment knob until it is all the way out and will turn no further.
 24. The regulator is now ready for service.

GO Regulator

405 Centura Court • PO Box 4866 • Spartanburg, SC 29303

Phone (864) 574-7966 • Fax (864) 574-5608

www.goreg.com • sales-go@circor.com