

PR-56 Series High Pressure Regulator Adjusting Knob Installation Instructions

Make sure you thoroughly understand these directions before proceeding
MAKE SURE THE REGULATOR IS DISCONNECTED FROM AIR SOURCE
MAKE SURE ANY RESIDUAL PRESSURE IS BLED OFF FROM REGULATOR.

Instructions

1. Completely read these instructions before performing any of the operations.
2. Make sure the regulator is disconnected from pressure source; make sure any residual pressure is bled off from the regulator.
FAILURE TO DO THIS WILL RESULT IN SERIOUS PERSONAL INJURY. DO NOT PROCEED UNTIL PRESSURE HAS BEEN REMOVED AND/OR TERMINATED
3. Securely clamp the regulator body over the flats in a vise.
4. Using a 7/16" wrench, turn the adjustment screw counterclockwise, as looking from the top of the regulator, until it will turn no further.
5. Place one of the thrust plates of the thrust bearing over the hexagonal end of the adjusting screw. Apply a liberal amount of grease.
6. Place the bearing race on top of the thrust plate. Apply a liberal amount of grease.
7. Place the other plate over the bearing race.
8. Place the knob on the end of the adjusting screw and line up the hex. Push down by hand as far as it will go.
9. Place the washer and knob screw on top of adjusting screw.
10. Using a 1/2" wrench, tighten the hex screw to a maximum value of 20 lbf·in (2 N·m). DO NOT OVER TIGHTEN. Over tightening will cause excessive load on the upper thrust bearing which will make the knob very hard to turn.
11. The regulator is now ready for service.

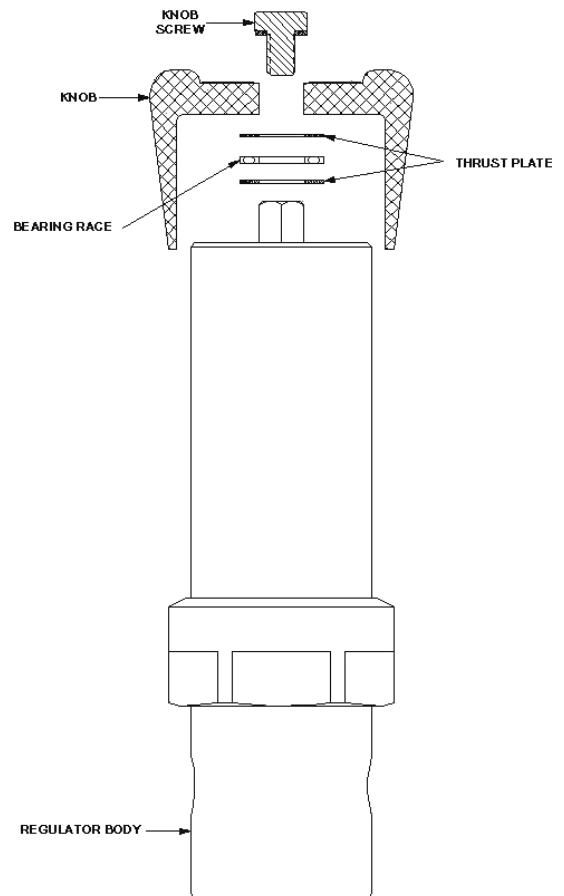

GO Regulator

405 Centura Court • PO Box 4866 • Spartanburg, SC 29303
Phone (864) 574-7966 • Fax (864) 574-5608
www.goreg.com • sales@goreg.com