

PR-56 Series High Pressure Regulator Non Self-Relieving Series O-ring Replacement Instructions

Make sure you thoroughly understand these directions before proceeding
MAKE SURE THE REGULATOR IS DISCONNECTED FROM AIR SOURCE
MAKE SURE ANY RESIDUAL PRESSURE IS BLEDED OFF FROM REGULATOR.

Instructions

1. Completely read these instructions before performing any of the operations.
2. Make sure the regulator is disconnected from pressure source; make sure any residual pressure is bled off from the regulator.
FAILURE TO DO THIS WILL RESULT IN SERIOUS PERSONAL INJURY. DO NOT PROCEED UNTIL PRESSURE HAS BEEN REMOVED AND/OR TERMINATED
3. Securely clamp the regulator body over the flats in a vise.
4. Turn the adjustment knob counterclockwise, as looking from the top of the regulator, until it will turn no further.
5. Using a 2 ¼" wrench, remove the spring housing assembly from the body.
6. Remove the range spring.
7. Remove the lower spring guide and piston / cylinder assembly.
8. Carefully remove cavity O-ring from regulator body and discard.
9. Thoroughly blow out the inside of regulator body using clean, dry compressed air.
10. Clean O-ring surface with a cotton swab moistened with isopropyl alcohol.
11. Apply O-ring lubricant, such as Krytox grease, into groove in regulator body if new cavity O-ring is dark color. Do not apply lubricant to groove if new O-ring is white color. Install new cavity O-ring into groove.
12. Remove piston assembly from cylinder.
13. Remove O-ring and back-up ring from piston and discard.
14. Install small O-ring over piston.
15. Install back-up ring over piston. Slide it all the way against the O-ring. Make sure that the O-ring and back up ring are oriented correctly.
16. Apply O-ring lubrication to small outside diameter of piston. Install piston into cylinder.
17. Place piston / cylinder assembly into regulator cavity.
18. Place lower spring guide onto the end of the piston.
19. Place range spring onto lower spring guide.
20. Place a small amount of Krytox or other lubricant on the outer threads of the body.
21. Put the spring housing assembly over the regulator and engage threads by hand. Tighten hand tight.
22. Finish tightening spring housing assembly to 80 lbf·ft (108 N·m).
23. Attach a pressure gauge and quarter-turn valve to the outlet port. Leave the valve in the closed position.
24. Turn the knob clockwise to get outlet pressure equal to the normal operating pressure that this regulator will be used at.

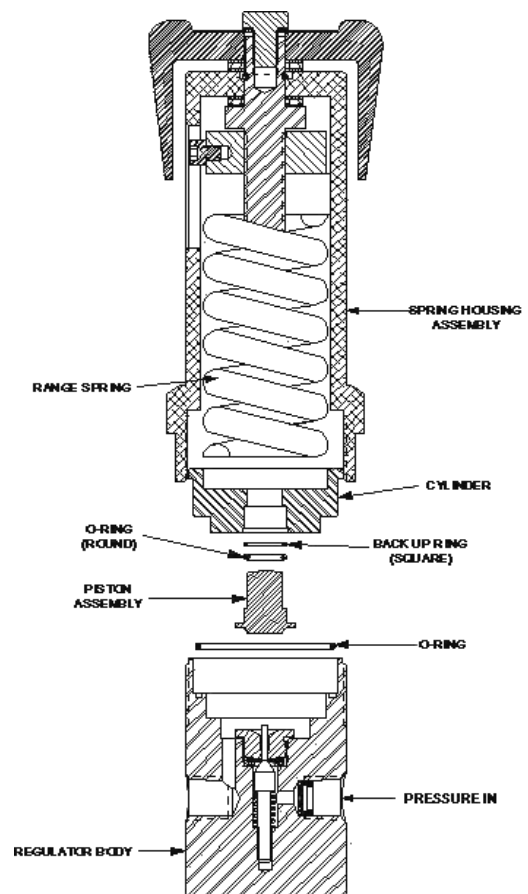

25. Squirt a leak detecting fluid around the base of the spring housing where it meets the body. Agitate the leak detecting fluid to form foam. Apply this foam around the slot in the spring housing while watching for signs of escaping gas.
26. Slowly turn the knob while watching and listening for any leaks. It may be necessary to re-apply the foam. If leaks are noticed, immediately back off knob and repair unit as needed.
27. If no leaks are noticed, adjust pressure to a value that is 110% of the maximum rating for this regulator.
28. Note the pressure reading on the gauge. Wait for 5 minutes. Increasing pressure indicates a leak across the seat or flat seal. Decreasing pressure indicates a possible O-ring leak. If the pressure does not remain stable, the unit must be disassembled and the cause of leakage repaired.
29. If no leaks are present, the regulator is now ready for service.

GO Regulator

405 Centura Court • PO Box 4866 • Spartanburg, SC 29303

Phone (864) 574-7966 • Fax (864) 574-5608

www.goreg.com • sales@goreg.com