

CPR-1 Series Regulators Diaphragm Replacement Instructions

**Make sure you thoroughly understand these directions before proceeding
MAKE SURE THE REGULATOR IS DISCONNECTED FROM AIR SOURCE
MAKE SURE ANY RESIDUAL PRESSURE IS BLED OFF
FROM REGULATOR.**

1. Completely read these instructions before performing any of the operations.
2. Make sure the regulator is disconnected from pressure source; make sure any residual pressure is bled off from the regulator. **FAILURE TO DO THIS WILL RESULT IN SERIOUS PERSONAL INJURY. DO NOT PROCEED UNTIL PRESSURE HAS BEEN REMOVED AND/OR TERMINATED**
3. Securely clamp the regulator over the flats in a vise.
4. Turn the knob counterclockwise as far as it will go. This should allow enough room for a standard adjustable end wrench to fit on the flats of the cap. Otherwise you will have to loosen the set screw on the knob using a 3/32 Allen wrench and remove the knob.
5. Remove the cap and adjusting screw as a unit. The range spring will be securely held inside the cap if this unit is equipped with a spring stabilizer. Earlier models do not have a stabilizer, in which case the range spring will be sitting on top of the diaphragm.
6. Remove the PTFE slip washer.
7. Remove the diaphragm assembly.
8. Remove the large Viton O-ring in the cavity.
9. Thoroughly clean out the cavity with compressed air and/or a swab.
10. Coat the new o-ring with a suitable lubricant, such as Krytox, and place it in the groove inside the cavity.
11. Place new diaphragm assembly onto regulator cavity.
12. Place new slip washer inside the cavity on top of the diaphragm assembly.
13. Place range spring and spring button onto diaphragm assembly unless it was equipped with a stabilizer and is inside the cap.
14. Place a small amount of Krytox or other lubricant on the outer threads of the regulator cap.
15. Put the cap over the regulator and engage threads by hand. Tighten hand tight.
16. Finish tightening cap to 40 lbf·ft (54 N·m).
17. Attach a pressure gauge and quarter-turn valve to the outlet port. Leave the valve in the open position.
18. Reinstall the knob on the adjusting screw if it has been removed, being careful to line up the flat on the adjusting screw with the set screw in the knob.
19. Slowly turn the knob clockwise. When there is evidence of flow at the quarter-turn valve close it.
20. Squirt a leak detecting fluid around the base of the cap where it meets the body. Agitate the fluid to form foam

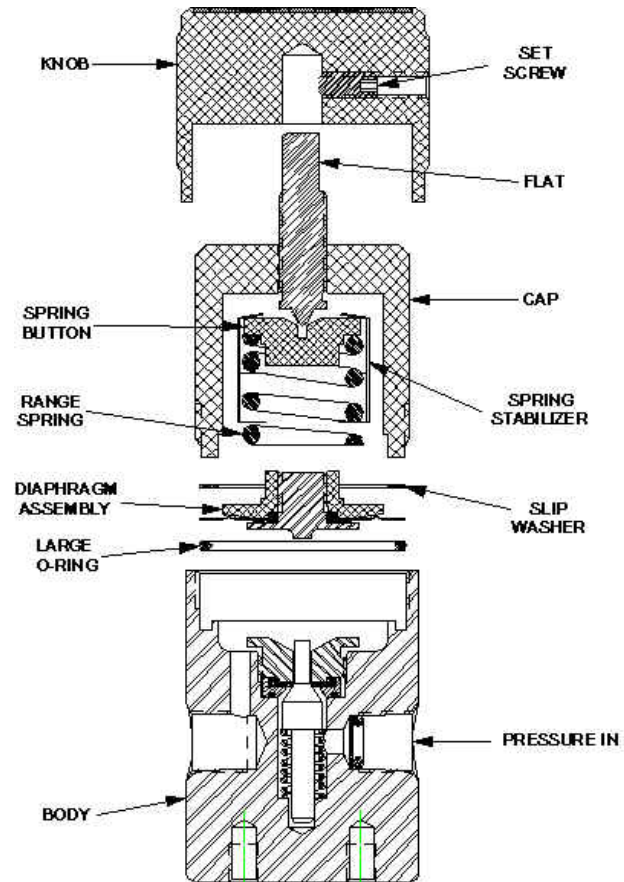

and apply around the 0.125 (3.1mm) leak detection port in the bonnet of the cap.

21. Slowly continue turning the knob while watching and listening for any leaks. It may be necessary to re-apply the liquid. If leaks are noticed, immediately back off adjusting screw and repair unit as needed.
22. If no leaks are noticed, adjust control pressure to a value that is 110% of the maximum rating for this regulator. Reapply the leak detecting fluid as needed.
23. Note the pressure reading on the gauge. Wait for 5 minutes. Increasing pressure indicates a leak across the seat or flat seal. Decreasing pressure indicates a possible diaphragm leak. If the pressure does not remain stable, the unit must be disassembled and the cause of leakage repaired.
24. Relieve the outlet pressure while backing off on the adjusting knob. Continue backing off on adjustment knob until it is all the way out and will turn no further.
25. The regulator is now ready for service.

GO Regulator

405 Centura Court • PO Box 4866 • Spartanburg, SC 29303

Phone (864) 574-7966 • Fax (864) 574-5608

www.goreg.com • sales-go@circor.com