

## SPR Series Pressure Regulator Poppet, Seat & Spring Replacement Instructions

**Make sure you thoroughly understand these directions before proceeding**  
**MAKE SURE THE REGULATOR IS DISCONNECTED FROM AIR SOURCE**  
**MAKE SURE ANY RESIDUAL PRESSURE IS BLED OFF FROM REGULATOR.**

### Instructions

1. Completely read these instructions before performing any of the operations.
2. Make sure the regulator is disconnected from pressure source; make sure any residual pressure is bled off from the regulator.  
**FAILURE TO DO THIS WILL RESULT IN SERIOUS PERSONAL INJURY. DO NOT PROCEED UNTIL PRESSURE HAS BEEN REMOVED AND/OR TERMINATED**
3. Securely clamp the regulator over the flats in a vise.
4. Turn the knob counterclockwise as far as it will go. This should allow enough room for a standard adjustable end wrench to fit on the flats of the cap. Otherwise you will have to remove the pry-out plug from top of knob, remove knob nut and unscrew knob from adjusting screw
5. Remove the cap and adjusting screw as a unit. The range spring will be securely held inside the cap if this unit is equipped with a spring stabilizer. Earlier models do not have a stabilizer, in which case the range spring will be sitting on top of the diaphragm.
6. Remove the foam damper and diaphragm, unless the diaphragm assembly remained in the cap. This is perfectly normal and can be left there.
7. Remove the large and small vacuum resist springs.
8. Using a 1 1/8" socket, loosen and remove the sub-seat.
9. Remove the poppet and poppet spring.
10. Thoroughly blow out the inside of regulator body using clean, dry compressed air. Make sure that the poppet guide is not dislodged.
11. Clamp sub-seat in a vise over the 1 1/8 hex.
12. Using a 5/8" socket, remove the seat from the sub-seat.
13. Clean seat surface with a cotton swab moistened with isopropyl alcohol.
14. Install new lower flat seal into groove of new seat.
15. Install new seat into sub-seat.
16. Start the threads of the seat by hand and tighten finger tight.
17. Finish tightening seat to 25 lbf·ft (34 N·m).
18. Carefully work new O-ring over the threads of the sub-seat.
19. Insure that the lower poppet guide is still in the body.
20. Place new poppet spring into the hole in the body.
21. Place new poppet into poppet spring.
22. Start the threads of the sub-seat in the body by hand. Continue tightening until finger tight.
23. Finish tightening sub-seat to 25 lbf·ft (34 N·m). (15 lbf·ft (20 N·m) for brass body)

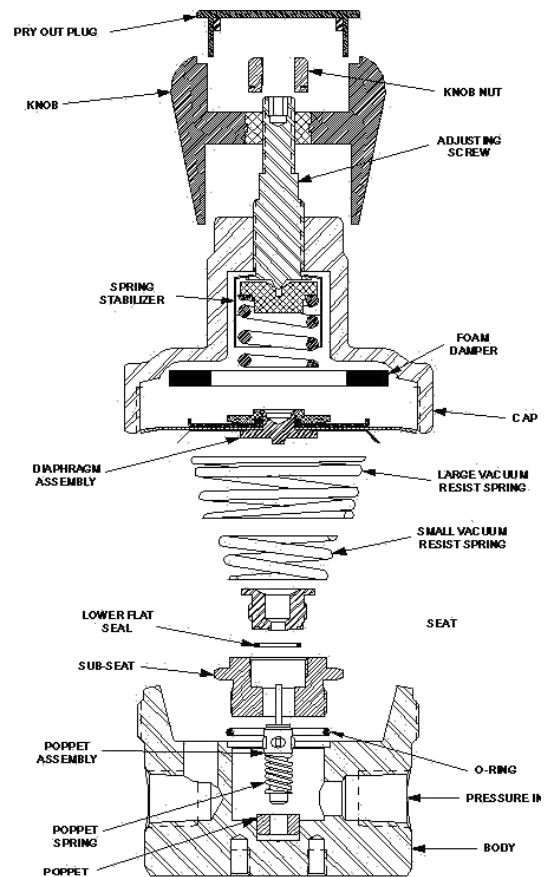

24. Attach primary pressure supply to inlet with suitable fittings.
25. Apply a small amount of leak detecting fluid, such as Leak Detective or soapy water, around poppet stem, seat retainer and sub-seat.
26. Slowly apply pressure to unit, watching closely for the presence of bubbles. Continue increasing inlet pressure up to one-half the maximum rated pressure for this unit. Let stand for 30 seconds. If there is evidence of leaking, such as bubbles or frothing, immediately relieve the primary pressure. The unit must be disassembled and inspected for foreign debris. If there is no evidence of leaking, clean out the leak detecting fluid and proceed to the next step.
27. Place the large and small vacuum resist springs in the cavity of the regulator. Make sure they are oriented correctly.
28. Place diaphragm assembly onto regulator cavity, unless it remained in the cap.
29. Place range spring and spring button onto diaphragm assembly unless it was equipped with a stabilizer and is inside the cap.
30. Place a small amount of Krytox or other lubricant on the outer threads of the body if the regulator body is steel. Do not apply lubricant to threads if regulator body is brass.
31. Put the cap over the regulator and engage threads by hand. Tighten hand tight.
32. Finish tightening cap to 60 lbf·ft (81 N·m). (40 lbf·ft (54 N·m) with PTFE / viton diaphragm).
33. Attach a pressure gauge and quarter-turn valve to the outlet port. Leave the valve in the open position.
34. Use a 5/32" allen wrench and slowly turn adjusting screw clockwise. When there is evidence of flow at the quarter-turn valve close it.
35. Squirt a leak detecting fluid around the base of the cap where it meets the body and around the 0.125 (3.1mm) leak detection port in the bonnet of the cap.
36. Slowly continue turning the adjusting screw while watching and listening for any leaks. It may be necessary to re-apply the liquid. If leaks are noticed, immediately back off adjusting screw and repair unit as needed.
37. If no leaks are noticed, adjust control pressure to a value that is 110% of the maximum rating for this regulator. Reapply the leak detecting fluid as needed.
38. Note the pressure reading on the gauge. Wait for 5 minutes. Increasing pressure indicates a leak across the seat or flat seal. Decreasing pressure indicates a possible diaphragm leak. If the pressure does not remain stable, the unit must be disassembled and the cause of leakage repaired.

### **If knob was removed:**

- Spin the knob as far down as it will go on the adjusting screw.
  - Tighten the knob nut against the metal insert, being careful not to change the position of the knob while doing this.
  - Install pry-out plug into top of knob.
39. Relieve the outlet pressure while backing off on the adjusting knob. Continue backing off on adjustment knob until it is all the way out and will turn no further.
  40. The regulator is now ready for service.

---

## **GO Regulator**

405 Centura Court • PO Box 4866 • Spartanburg, SC 29303  
Phone (864) 574-7966 • Fax (864) 574-5608  
[www.goreg.com](http://www.goreg.com) • [sales-go@circor.com](mailto:sales-go@circor.com)