

DHR Electrically Heated Vaporizing Regulator Wiring Instructions for TCO and non-TCO types

**Make sure you thoroughly understand these directions before proceeding
MAKE SURE THE REGULATOR IS DISCONNECTED FROM PRESSURE SOURCE
MAKE SURE ANY RESIDUAL PRESSURE IS BLED OFF FROM REGULATOR.**

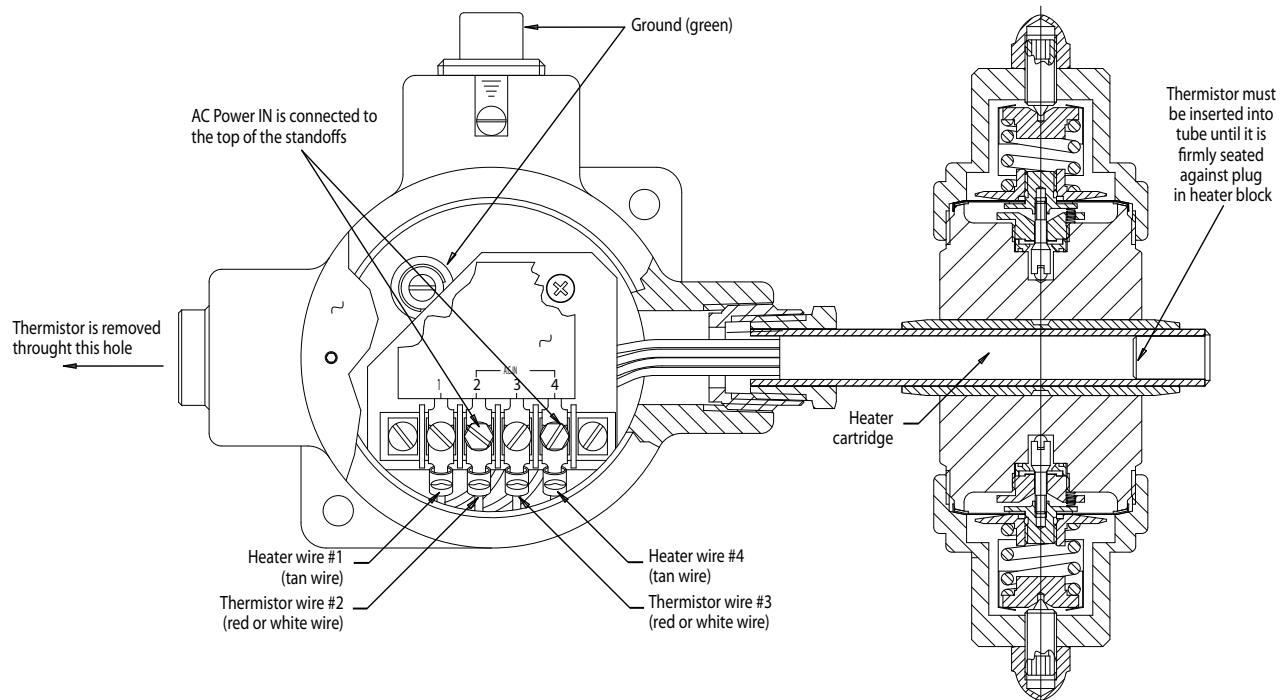

DISASSEMBLY

1. Make sure the regulator is disconnected from pressure source; make sure any residual pressure is bled off from the regulator. **FAILURE TO DO THIS WILL RESULT IN SERIOUS PERSONAL INJURY. DO NOT PROCEED UNTIL PRESSURE HAS BEEN REMOVED AND/OR TERMINATED**
2. Disconnect unit from AC power supply or terminate AC power supply at its source. **FAILURE TO DO THIS WILL RESULT IN SERIOUS PERSONAL INJURY. DO NOT PROCEED UNTIL AC POWER HAS BEEN REMOVED AND/OR TERMINATED.**
3. Unscrew condulet cap. If the condulet cap is equipped with a locking set screw, this must be loosened prior to unscrewing condulet cap.
4. Loosen and remove the screws that hold the AC feed wires. Carefully remove the AC feed wires and any conduit that is attached to the condulet. This leg of the condulet must be open to be able to remove the thermistor/heater assembly.
5. Loosen the standoffs with a socket. Loosen the screws at position 1 and 3 on the terminal strip and remove the controller.
6. Remove the two outside screws that hold the terminal strip onto the sub-plate. Remove the terminal strip.
7. Loosen and remove the two screws that hold the sub-plate onto the condulet. Remove the sub-plate.
8. Carefully feed the wires of the thermistor/heater assembly through the hole on the opposite side of the condulet. Continue pulling on the wires, gradually increasing the load just until the thermistor/heater assembly breaks loose. Feed the loose thermistor/heater assembly all the way through the hole in the condulet.

ASSEMBLY

1. Slide the thermistor/heater assembly through the open leg of the conduit. Continue inserting the thermistor/heater assembly until it is firmly seated against the bottom of the bore (refer to the drawing). Failure to do this will cause improper heating of the unit and could lead to failure of the unit.
2. Place the sub-plate over the wires of the thermistor/heater assembly and leave the spade connectors extending up as indicated in the drawing. Be careful not to crimp or pinch the wires under the plate. Pull up enough slack in the wires to facilitate the connection to the terminal strip, but DO NOT pull the thermistor/heater assembly away from the bottom of the bore. The wires must be run under the sub-plate to prevent damaging them when the conduit cap is installed.
3. Using the two screws, tighten the sub-plate onto the conduit.
4. Using the two outside screws for the terminal strip, tighten it onto the sub-plate.
5. Insert the controller onto the middle four leads, making sure the AC standoffs will be on terminals 2 and 4.
6. Carefully feed the spade connectors onto the correctly numbered terminals. Failure to match up the numbered leads with the right terminal will cause failure of the unit and pose a risk of injury to the technician.
7. Tighten the screws and standoffs down.
8. Feed in the AC power supply and connect to the top of the standoffs located at terminals 2 and 4.
9. Connect the ground wire to either the internal GREEN grounding screw, or to the external GREEN grounding screw. Failure to properly ground this unit will pose a safety hazard.
10. Screw down the conduit cap and tighten.

GO Regulator

405 Centura Court • PO Box 4866 • Spartanburg, SC 29303

Phone (864) 574-7966 • Fax (864) 574-5608

www.goreg.com • sales@goreg.com