

HPR-2XW Electric Series Vaporizer Replacement Instructions

**Make sure you thoroughly understand these directions before proceeding
MAKE SURE THE REGULATOR IS DISCONNECTED FROM AIR SOURCE
MAKE SURE ANY RESIDUAL PRESSURE IS BLEDED OFF FROM REGULATOR.**

Disassembly

1. Make sure the regulator is disconnected from pressure source; make sure any residual pressure is bled off from the regulator. **FAILURE TO DO THIS WILL RESULT IN SERIOUS PERSONAL INJURY. DO NOT PROCEED UNTIL PRESSURE HAS BEEN REMOVED AND/OR TERMINATED**
2. Disconnect unit from AC power supply or terminate AC power supply at its source. **FAILURE TO DO THIS WILL RESULT IN SERIOUS PERSONAL INJURY. DO NOT PROCEED UNTIL AC POWER HAS BEEN REMOVED AND/OR TERMINATED.**
3. Securely clamp the heater block over the flats in a vise. It is not recommended to remove the regulator body from the heater block.
4. Loosen the vaporizer screen assembly using a 5/8 socket.
5. Unscrew and remove the assembly all of the way. The screen portion of the assembly can sometimes stick in the heater block and not come out with the rest of the assembly. Use a pair of needle nose pliers to remove the screen if it becomes stuck. Be careful not to damage the seat area of the heater block.
6. Clean the seat area and bore of the heater block using compressed air and pipe cleaners. Visually inspect these areas for debris and/or damage before installing the new vaporizer screen assembly.

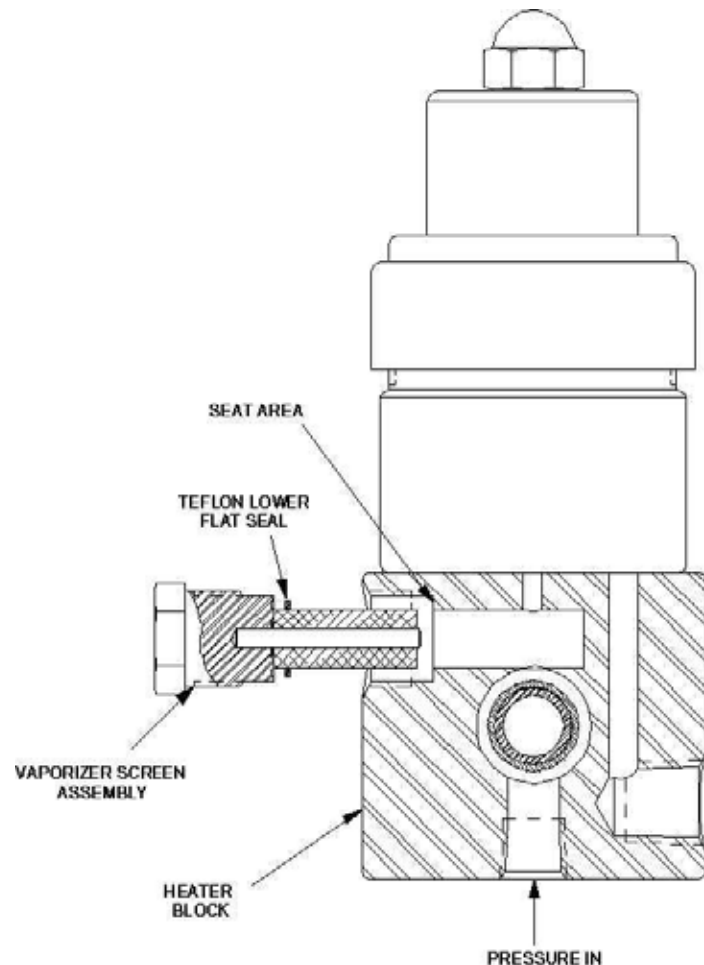

Assembly

1. Put a small amount of lubricant, such as Krytox, on the threads of the vaporizer screen assembly.
2. Make sure that the PTFE lower flat seal is seated properly.
3. Carefully insert the vaporizer screen assembly and start the threads by hand. Continue screwing in by hand until finger tight.
4. Finish tightening the assembly with a torque wrench to a value of 25 lbf·ft (34 N·m).

5. Attach a pressure supply of non-hazardous gas, such as Nitrogen or compressed air, to inlet with suitable fittings.
6. Apply a small amount of leak detecting fluid, such as "Leak Detective" or soapy water, around hex head of the vaporizer screen assembly.
7. Slowly apply pressure to unit, watching closely for the presence of bubbles. Continue increasing inlet pressure up to the maximum rated pressure for this unit. Let stand for 30 seconds. If there is evidence of leaking, such as bubbles or frothing, immediately relieve the primary pressure. The unit must be disassembled and inspected for foreign debris.
8. If there is no evidence of leaking, clean off the leak detecting fluid and remove the inlet pressure. The unit is now ready for service.

GO Regulator

405 Centura Court • PO Box 4866 • Spartanburg, SC 29303

Phone (864) 574-7966 • Fax (864) 574-5608

www.goreg.com • sales-go@circor.com