

CPR-5 Series

Compact Stainless Steel Pressure Regulator



The CPR-5 Series pressure control valve is designed for service at high flows with good sensitivity and regulation utilizing a small footprint. While the design was originated for gas systems, this valve is perfectly suitable for liquid systems that are compatible with the materials of construction. Also of interest is the fact that while being able to perform with moderately high flows, this valve also provides very good performance in flow ranges of only a few liters a minute.

This series is a variation of the time proven CPR-1 Series which has been used for many applications in systems requiring stainless steel construction. The exact package size of the CPR-1 has been retained making it convenient for the user to interchange these units if better control at higher flows is required.

Features & Specifications

- Gas or liquid service
- 316L stainless steel construction
- PTFE/stainless steel diaphragm up to 250 psig
- PTFE/Viton® diaphragm up to 50 psig
- Electropolished body with better than 25 Ra finish in diaphragm
- 40 micron inlet filter
- Bubble-tight shutoff
- Outlet pressure ranges are 0–10, 0–25, 0–50, 0–100 and 0–250 psig
- Cv flow coefficient 0.2

pressure regulators

How to Order

CPR5 -

BODY MATERIAL

- 1 316L stainless steel

PORT CONFIGURATION

- A Standard
- For more port configurations, see page 33.

PROCESS PORT TYPES

(GAUGE PORT TYPES, IF SPECIFIED)

- 0 1/8" FNPT (1/8" FNPT gauge ports)

SURFACE FINISH OF DIAPHRAGM CAVITY

- 1 < 25 Ra

SEAT MATERIAL

- D Viton®
- J Buna N
- K Kalrez®

FLOW COEFFICIENT (Cv)

- 5 0.2

OPTIONS

- A EB33
- B EB5
- D Helium leak test
- E Pressure test certificate
- F Certificate of Conformity
- G CMTR

CAP ASSEMBLY

- 1 Standard, aluminum
- 4 Panel mount, aluminum
- 5 Captured vent, aluminum
- 7 Captured vent, stainless steel
- 8 Tamper-proof, aluminum
- 9 Fine adjust, 1/2" panel mount, aluminum
- 0 Fine adjust, 1 3/8" panel mount, aluminum

DIAPHRAGM FACING/BACKING/

O-RING MATERIAL

- 1 Tefzel® ring/stainless steel/PTFE
- 2 PTFE/Viton®/Viton®
- 3 PTFE/Viton®/PTFE
- 7 Tefzel® ring/stainless steel/Viton®
- 8 Tefzel® ring/INCONEL®/PTFE
- H Tefzel® ring/INCONEL®/Viton®

DIAPHRAGM TYPE

- 1 Standard, Nylon dia. slip ring (170° F maximum temperature)
- 2 Standard, Polyimide dia. slip ring (high temperature service)

OUTLET RANGE

- C 0-10 psig
- D 0-25 psig
- E 0-50 psig
- G 0-100 psig
- I 0-250 psig

NOTE: Contact the factory for any additional requirements.

Maximum Temperature & Operating Inlet Pressures

SEAT MATERIAL	MAXIMUM TEMPERATURE	@	MAXIMUM OPERATING INLET PRESSURE
Viton®	400° F (204° C)	@	300 psig (2.07 MPa)
Buna N	150° F (66° C)	@	300 psig (2.07 MPa)
Kalrez®	400° F (204° C)	@	300 psig (2.07 MPa)

Outline and Mounting Dimensions

Weight = 1.1 lbs (0.50kg)

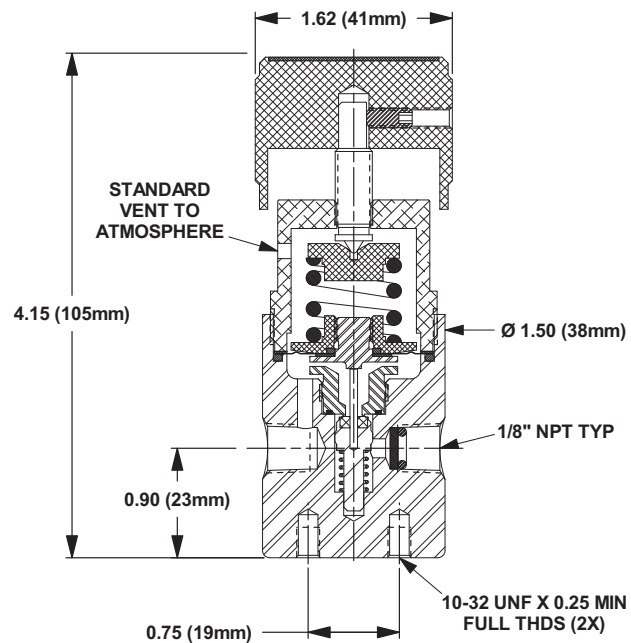

Tefzel® is a registered trademark of the DuPont Company.
 Kalrez® and Viton® are registered trademarks of DuPont Dow Elastomers.