

DL-59 Series

Dome-loaded Pressure Regulator

Responding to the needs of the industry for a simple, safe and effective way to remotely load high pressure regulators, GO Regulator designed and developed a line of low profile dome loading units.

This compact and robust design employs a unique “Dual Piston” set up which enables the user to control pressure up to 4000 psig (276 bar) with as little as 36 psig (2 bar) of dome pressure. All of this is accomplished within the smallest envelope the industry has to offer!

The regulator portion of this unit was patterned after the time tested PR-59 Series, which is widely recognized as a benchmark of performance and quality. Offering the utmost in safety and corrosion prevention, this unit is constructed from 316L stainless steel. A carefully engineered piston sensor unit offers good sensitivity and repeatability. This is coupled with the large Cv of the PR-59 of 1.20.

Completing this design is the addition of a 316 stainless steel dome unit. The inlet ring to the dome is freely rotating and captured by a high tensile snap ring. This feature allows easy positioning and alignment of the dome gas line within a customer’s system while maintaining excellent leak integrity.



pressure regulators

Typical Applications

- Pilot plant
- Pneumatic high flow test benches
- Bulk gas delivery
- R & D systems

Technical Data

CONSTRUCTION	316L stainless steel construction (Brass and MONEL® optional)
DOMES RATIOS	11:1, 20:1, 43:1, 56:1, 76:1, 108:1, 122:1, and 172:1
OUTLET PRESSURES	up to 4000 psig (276 bar)
Cv COEFFICIENTS	1.2 (standard)

Features & Benefits

- Gas or liquid service
- Better than 25 Ra finish in diaphragm cavity
- Stainless steel piston sensor
- 20 micron inlet filter
- Bubble-tight shutoff

DL-59 Series

To Order, contact your local Distributor Link below:
www.goreg.com/distributor/index.htm

Verify that your chosen part number is valid using the GO Wizards at
www.goreg.com/products/matrix/index.htm

How to Order

Standard items in bold.

DL59 – 1 A A 1 H 9 0 1 5 3 A

BODY MATERIAL

- 1 **316L stainless steel**
- 2 Brass
- 4 MONEL®

PORT CONFIGURATIONS

- A **Standard**
- For more port configurations, see page 9.

PROCESS PORT TYPES

(GAUGE PORT TYPE, IF SPECIFIED)

- 5 1/2" FNPT (1/4" FNPT gauge ports)
- A 3/4" FNPT (1/4" FNPT gauge ports)

SURFACE FINISH OF DIAPHRAGM CAVITY

- 1 < 25 Ra

SEAT MATERIAL

- H **PCTFE**
- I PTFE

OPTIONS

- A EB33 (oxygen cleaning)
- B EB5 cleaning
- D Helium leak test
- E Pressure test certificate
- F Certificate of Conformity
- G CMTR

DOME STYLE

- 3 **Stainless steel, standard**
- 4 Captured vent, stainless steel

PISTON MATERIAL

- 5 **Stainless steel**
- B MONEL®

PISTON TYPE

- 1 Non-self-relieving
- 3 Self-relieving

DOME RATIO

- 0 11:1
- 1 43:1
- 2 56:1
- 3 76:1
- 4 108:1
- 5 122:1
- 6 172:1
- 7 20:1

FLOW COEFFICIENT (Cv)

- 9 1.2

For flow curve charts, visit <http://www.goreg.com>.

NOTE: Contact the factory for any additional requirements.

Maximum Temperature & Operating Inlet Pressures

SEAT MATERIAL	MAXIMUM TEMPERATURE	@	MAXIMUM OPERATING INLET PRESSURE
PCTFE	175° F (80° C)	@	4000 psig (276 bar)
PTFE	150° F (66° C)	@	1000 psig (69 bar)

Outline and Mounting Dimensions

Weight = 8.4 lbs (3.8kg)

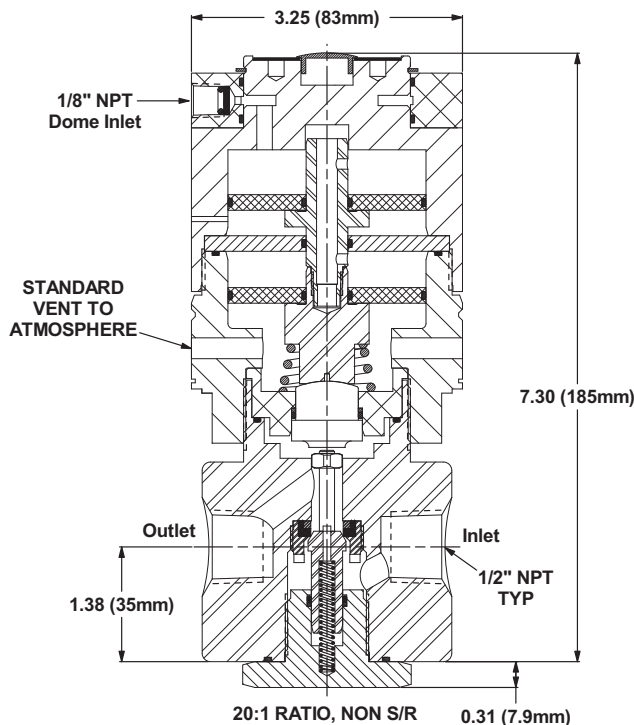

MONEL® is a registered trademark of Special Metals Corporation.
 Kel-F® is a registered trademark of 3M Company.