

GO REGULATOR, INC.

Dome Loaded Pressure Regulators

Index

Safety Warning	Inside Front Cover
DL-50	1
DL-56	3
DL-57	5
DL-59	7
Porting Configurations	9
Disclaimers	Inside Back Cover



pressure regulators



CRANE Instrumentation & Sampling, Go Regulator
PO Box 4866 • Spartanburg, SC 29305-4866
(864) 574-7966 • www.goreg.com

For Your Safety

It is solely the responsibility of the system designer and user to select products suitable for their specific application requirements and to ensure proper installation, operation, and maintenance of these products. When selecting products, the total system design must be considered to ensure safe, trouble-free performance. Material compatibility, product ratings and application details should be considered in the selection. Improper selection or use of products described herein can cause personal injury or property damage.

Contact your authorized GO Regulator sales and service representative for information about additional sizes and special alloys.

SAFETY WARNING:

GO Regulator products are designed for installation only by professional suitably qualified licensed system installers experienced in the applications and environments for which the products are intended. These products are intended for integration into a system. Where these products are to be used with flammable or hazardous media, precautions must be taken by the system designer and installer to ensure the safety of persons and property. Flammable or hazardous media pose risks associated with fire or explosion, as well as burning, poisoning or other injury or death to persons and/or destruction of property. The system designer and installer must provide for the capture and control of such substances from any vents in the product(s). The system installer must not permit any leakage or uncontrolled escape of hazardous or flammable substances. The system operator must be trained to follow appropriate precautions and must inspect and maintain the system and its components including the product(s) and at regular intervals in accordance with timescales recommended by the supplier to prevent unacceptable wear or failure.

DL-50 Series

Dome-loaded Pressure Regulator

The DL-50 is a compact and robust design which employs a unique “Dual Piston” set up that enables the user to control pressure up to 6000 psig (414 bar) with as little as 100 psig (7 bar) of dome pressure. All of this is accomplished within the smallest envelope the industry has to offer.

The regulator portion of this unit was patterned after the time tested PR-50 Series, which is widely recognized as a benchmark of performance and quality. Offering the utmost in economy and safety, this unit is constructed from 316L stainless steel. A carefully engineered diaphragm/piston sensor unit offers good sensitivity and repeatability.

Completing this design is the addition of a 316 stainless steel dome unit. The inlet ring to the dome is freely rotating and captured by a high tensile snap ring. This feature allows easy positioning and alignment of the dome gas line within a customer’s system while maintaining excellent leak integrity.



pressure regulators

Typical Applications

- Pilot plant
- Off-shore oil and gas rigs
- Pneumatic test benches
- Component testing
- R & D systems
- High pressure booster systems

Features & Benefits

- Gas or liquid service
- Better than 25 Ra finish in diaphragm cavity
- 20 micron inlet filter
- Bubble-tight shutoff
- Diaphragm type sensing
- Remote dome-loading

Technical Data

CONSTRUCTION	316L stainless steel construction (Brass and MONEL® optional)
DOMES RATIOS	11.5 : 1, 20 : 1
INLET/OUTLET PORTS	¼" FNPT (standard)
OUTLET PRESSURE	up to 2000 psig (138 bar)
Cv COEFFICIENTS	0.025, 0.06, 0.2

DL-50 Series

To Order, contact your local Distributor Link below:
www.goreg.com/distributor/index.htm

Verify that your chosen part number is valid using the GO Wizards at
www.goreg.com/products/matrix/index.htm

How to Order

Standard items in bold.

DL50 - 1 A 1 1 C 3 1 1 6 3 A

BODY MATERIAL

- 1** 316L stainless steel
- 2 Brass
- 4 MONEL®

PORT CONFIGURATIONS

A Standard

For more port configurations, see page 9.

PROCESS PORT TYPES

(GAUGE PORT TYPE, IF SPECIFIED)

- 1** ¼" FNPT (¼" FNPT gauge ports)
- 4 ⅜" FNPT (¼" FNPT gauge ports)

SURFACE FINISH OF DIAPHRAGM CAVITY

- 1** < 25 Ra
- 5 < 25 Ra with 10-32 mounting holes

SEAT MATERIAL

- A** Tefzel®
- H** PCTFE
- Q** PEEK™

OPTIONS

- A** EB33 (oxygen cleaning)
- B** EB5 cleaning
- D** Helium leak test
- E** Pressure test certificate
- F** Certificate of Conformity
- G** CMTR

DIAPHRAGM FACING/BACKING MATERIAL

	Facing	Backing	O-rings	Actuator
1	St. steel	Nylon	Viton®	St. steel
2	—	Nylon	PTFE	St. steel
3	Polyimide	Nylon	Viton®	St. steel
4	St. steel	Nylon	PTFE	St. steel
5	—	Nylon	PTFE	MONEL®
6	Polyimide	Nylon	PTFE	St. steel
7	INCONEL®	Nylon	Viton®	MONEL®
8	INCONEL®	Nylon	PTFE	MONEL®
B	—	Nylon	Viton®	MONEL®
H	—	Nylon	Viton®	St. steel
Q	St. steel	PTFE	PTFE	St. steel
V	INCONEL®	PTFE	PTFE	MONEL®

DIAPHRAGM TYPE

- 1** Non-self-relieving
- 3** Self-relieving

DIAPHRAGM RATIO

- 1** 11.5 : 1
- 2** 20 : 1

FLOW COEFFICIENT (CV)

- 3** **0.06**
- 5** 0.2
- C** 0.025

NOTE: Contact the factory for any additional requirements.

Maximum Temperature & Operating Inlet Pressures

Nylon Diaphragm Backing

SEAT MATERIAL	MAXIMUM TEMPERATURE	@	MAXIMUM OPERATING INLET PRESSURE
Tefzel®	150° F (66° C)	@	3600 psig (248 bar)
PCTFE	175° F (80° C)	@	6000 psig (414 bar)
PEEK™	175° F (80° C)	@	6000 psig (414 bar)

PTFE Diaphragm Backing

SEAT MATERIAL	MAXIMUM TEMPERATURE	@	MAXIMUM OPERATING INLET PRESSURE
Tefzel®	150° F (66° C)	@	3600 psig (248 bar)
PCTFE	175° F (80° C)	@	6000 psig (414 bar)
PEEK™	350° F (177° C)	@	6000 psig (414 bar)

MONEL® is a registered trademark of Special Metals Corporation.
 Tefzel® is a registered trademark of the DuPont Company.
 Kel-F® is a registered trademark of 3M Company.
 PEEK™ is a trademark of Victrex PLC.
 Viton® is a registered trademark of DuPont Dow Elastomers.

Outline and Mounting Dimensions

Weight = 5.1 lbs (2.31kg)

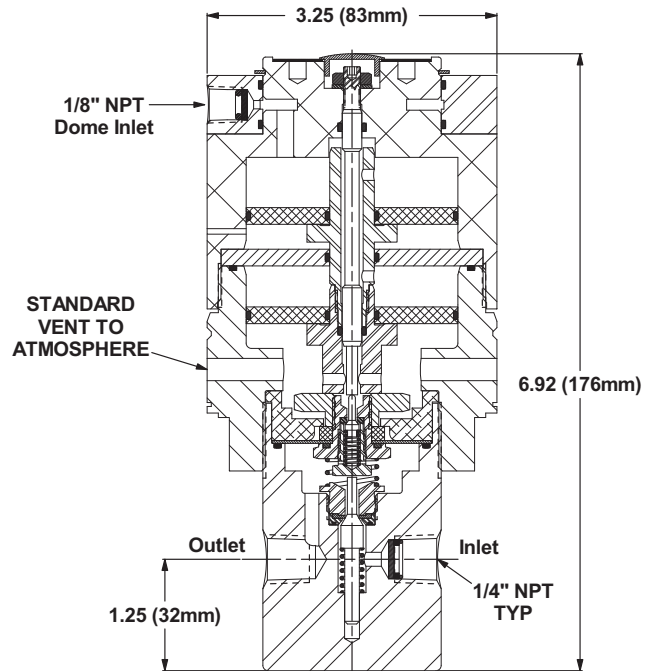

11.5:1 RATIO, S/R, 0.2 Cv

DL-56 Series

Dome-loaded Pressure Regulator

The DL-56 is a compact and robust design which employs a unique “Dual Piston” set up that enables the user to control pressure up to 6000 psig (414 bar) with as little as 40 psig (3 bar) of dome pressure. All of this is accomplished within the smallest envelope the industry has to offer.

The regulator portion of this unit was patterned after the time tested PR-56 Series, which is widely recognized as a benchmark of performance and quality. Offering the utmost in economy and safety, this unit is constructed from brass alloy 360. A carefully engineered all 316L stainless steel piston sensor unit offers good sensitivity and repeatability. An independent test was run and showed that the unit’s ability to repeat to a set point and low operating hysteresis is unsurpassed through out the industry.

Completing this design is the addition of a 316 stainless steel dome unit. The inlet ring to the dome is freely rotating and captured by a high tensile snap ring. This feature allows easy positioning and alignment of the dome gas line within a customer’s system while maintaining excellent leak integrity.



pressure regulators

Typical Applications

- Pilot plant
- Off-shore oil and gas rigs
- Pneumatic test benches
- Component testing
- R & D systems
- High pressure booster systems

Features & Benefits

- Gas or liquid service
- Better than 25 Ra finish in diaphragm cavity
- Stainless steel piston sensor
- 20 micron inlet filter
- Bubble-tight shutoff
- Remote dome-loading

Technical Data

CONSTRUCTION	Brass (alloy 360)
DOMES RATIOS	11 : 1, 20 : 1, 43 : 1, 56 : 1, 76 : 1, 108 : 1, 122 : 1 and 172 : 1
INLET/OUTLET PORTS	¼" FNPT (standard)
OUTLET PRESSURES	up to 6000 psig (414 bar)
Cv COEFFICIENTS	0.05, 0.20

DL-56 Series

To Order, contact your local Distributor Link below:
www.goreg.com/distributor/index.htm

Verify that your chosen part number is valid using the GO Wizards at
www.goreg.com/products/matrix/index.htm

How to Order

Standard items in bold.

DL56 - 2 A 1 1 A 2 0 1 6 3 A

BODY MATERIAL

2 Brass

PORT CONFIGURATIONS

A Standard

For more port configurations, see page 9.

PROCESS PORT TYPES

(GAUGE PORT TYPE, IF SPECIFIED)

1 1/4" FNPT (1/4" FNPT gauge ports)

4 3/8" FNPT (1/4" FNPT gauge ports)

SURFACE FINISH OF DIAPHRAGM CAVITY

1 < 25 Ra

5 < 25 Ra with 10-32 mounting holes

SEAT MATERIAL

A Tefzel®

H PCTFE

Q PEEK™

OPTIONS

A EB33 (oxygen cleaning)

B EB5 cleaning

D Helium leak test

E Pressure test certificate

F Certificate of Conformity

G CMTR

DOME STYLE

3 Stainless steel, standard

4 Captured vent, stainless steel

PISTON MATERIAL

1 Stainless steel

PISTON TYPE

1 Non-self-relieving, Viton® cavity O-ring

2 Non-self-relieving, PTFE cavity O-ring

3 Self-relieving, Viton® cavity O-ring

4 Self-relieving, PTFE cavity O-ring

DOME RATIO

0 11 : 1

1 43 : 1

2 56 : 1

3 76 : 1

4 108 : 1

5 122 : 1

6 172 : 1

7 20 : 1

FLOW COEFFICIENT (Cv)

2 0.05

5 0.2

NOTE: Contact the factory for any additional requirements.

Maximum Temperature & Operating Inlet Pressures

SEAT MATERIAL	MAXIMUM TEMPERATURE	@	MAXIMUM OPERATING INLET PRESSURE
Tefzel®	150° F (66° C)	@	3600 psig (248 bar)
PCTFE	175° F (80° C)	@	6000 psig (414 bar)
PEEK™	175° F (80° C)	@	6000 psig (414 bar)

Outline and Mounting Dimensions

Weight = 5.4 lbs (2.45kg)

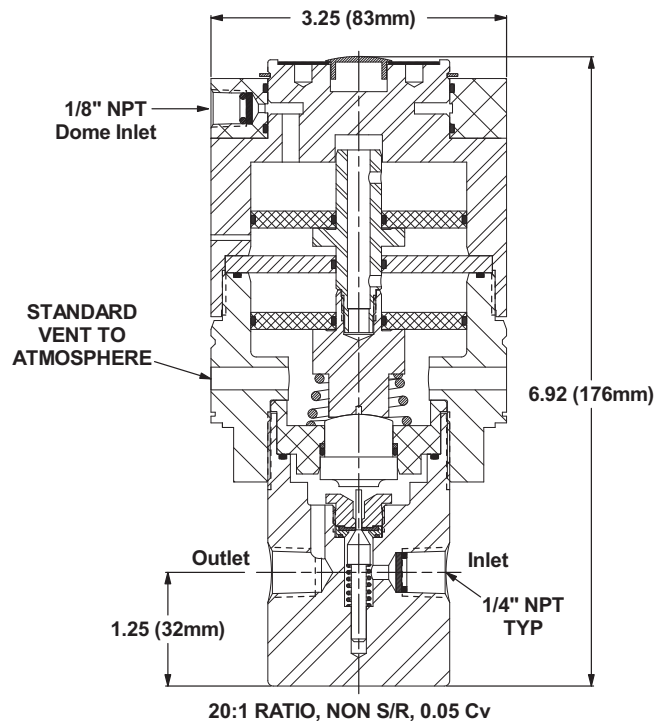

Tefzel® is a registered trademark of the DuPont Company.

Kel-F® is a registered trademark of 3M Company.

PEEK™ is a trademark of Victrex PLC.

Viton® is a registered trademark of DuPont Dow Elastomers.

DL-57 Series

Dome-loaded Pressure Regulator

The DL-57 is a compact and robust design which employs a unique “Dual Piston” set up that enables the user to control pressure up to 10,000 psig (689 bar) with as little as 58 psig(4 bar) of dome pressure. All of this is accomplished within the smallest envelope the industry has to offer.

The regulator portion of this unit was patterned after the time tested PR-57 Series, which is widely recognized as a benchmark of performance and quality. Offering the utmost in safety and corrosion prevention, this unit is constructed from 316L stainless steel. A carefully engineered piston sensor unit offers good sensitivity and repeatability. An independent test was run and showed that the unit’s ability to repeat to a set point and low operating hysteresis is unsurpassed through out the industry.

Completing this design is the addition of a 316 stainless steel dome unit. The inlet ring to the dome is freely rotating and captured by a high tensile snap ring. This feature allows easy positioning and alignment of the dome gas line within a customer’s system while maintaining excellent leak integrity.



pressure regulators

Typical Applications

- Pilot plant
- Off-shore oil and gas rigs
- Pneumatic test benches
- Component testing
- R & D systems
- High pressure booster systems

Features & Specifications

- Gas or liquid service
- Better than 25 Ra finish in diaphragm cavity
- Stainless steel piston sensor
- 20 micron inlet filter
- Bubble-tight shutoff
- Remote dome-loading

Technical Data

CONSTRUCTION	316L stainless steel construction (MONEL® optional)
DOMES RATIOS	11:1, 20:1, 43:1, 56:1, 76:1, 108:1, 122:1, and 172:1
INLET/OUTLET PORTS	¼" FNPT (standard)
OUTLET PRESSURES	up to 10,000 psig (689 bar)
Cv COEFFICIENTS	0.05, 0.20

DL-57 Series

To Order, contact your local Distributor Link below:
www.goreg.com/distributor/index.htm

Verify that your chosen part number is valid using the GO Wizards at
www.goreg.com/products/matrix/index.htm

How to Order

DL57 – 1 A 1 1 Q 2 3 1 1 3 A

BODY MATERIAL

- 1 316 stainless steel
- 2 MONEL®

PORT CONFIGURATIONS

- 1 Standard

For more port configurations, see page 9.

PROCESS PORT TYPES (GAUGE PORT TYPE, IF SPECIFIED)

- 1 ¼" FNPT (¼" FNPT gauge ports)
- 4 ⅜" FNPT (¼" FNPT gauge ports)

SURFACE FINISH OF DIAPHRAGM CAVITY

- 1 < 25 Ra
- 5 < 25 Ra with 10-32 mounting holes

SEAT MATERIAL

- C Polyimide
- Q PEEK™

OPTIONS

- B EB5 cleaning
- D Helium leak test
- E Pressure test certificate
- F Certificate of Conformity
- G CMTR

DOMESTYLE

- 3 Stainless steel, standard
- 4 Captured vent, stainless steel

PISTON MATERIAL

- 1 Stainless steel
- 4 MONEL®

PISTON TYPE

- 1 Non-self-relieving, Viton® cavity O-ring
- 2 Non-self-relieving, PTFE cavity O-ring
- 3 Self-relieving, Viton® cavity O-ring
- 4 Self-relieving, PTFE cavity O-ring

DOMERATIO

- 0 11:1
- 1 43:1
- 2 56:1
- 3 76:1
- 4 108:1
- 5 122:1
- 6 172:1
- 7 20:1

FLOW COEFFICIENT (Cv)

- 2 0.05
- 5 0.2

NOTE: Contact the factory for any additional requirements.

Maximum Temperature & Operating Inlet Pressures

SEAT MATERIAL	MAXIMUM TEMPERATURE	@	MAXIMUM OPERATING INLET PRESSURE
Polyimide	150° F (66° C)	@	10,000 psig (689 bar)
PEEK™	150° F (66° C)	@	10,000 psig (689 bar)

Outline and Mounting Dimensions

Weight = 5.4 lbs (2.45kg)

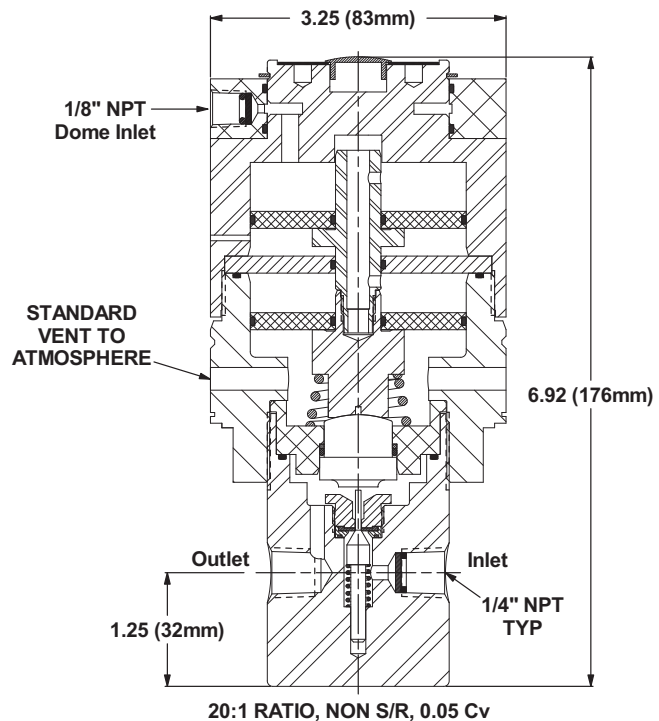

MONEL® is a registered trademark of Special Metals Corporation.
 PEEK™ is a trademark of Victrex PLC.
 Viton® is a registered trademark of DuPont Dow Elastomers.

DL-59 Series

Dome-loaded Pressure Regulator

Responding to the needs of the industry for a simple, safe and effective way to remotely load high pressure regulators, GO Regulator designed and developed a line of low profile dome loading units.

This compact and robust design employs a unique "Dual Piston" set up which enables the user to control pressure up to 4000 psig (276 bar) with as little as 36 psig (2 bar) of dome pressure. All of this is accomplished within the smallest envelope the industry has to offer!

The regulator portion of this unit was patterned after the time tested PR-59 Series, which is widely recognized as a benchmark of performance and quality. Offering the utmost in safety and corrosion prevention, this unit is constructed from 316L stainless steel. A carefully engineered piston sensor unit offers good sensitivity and repeatability. This is coupled with the large Cv of the PR-59 of 1.20.

Completing this design is the addition of a 316 stainless steel dome unit. The inlet ring to the dome is freely rotating and captured by a high tensile snap ring. This feature allows easy positioning and alignment of the dome gas line within a customer's system while maintaining excellent leak integrity.



pressure regulators

Typical Applications

- Pilot plant
- Pneumatic high flow test benches
- Bulk gas delivery
- R & D systems

Technical Data

CONSTRUCTION	316L stainless steel construction (Brass and MONEL® optional)
DOMES RATIOS	11:1, 20:1, 43:1, 56:1, 76:1, 108:1, 122:1, and 172:1
OUTLET PRESSURES	up to 4000 psig (276 bar)
Cv COEFFICIENTS	1.2 (standard)

Features & Benefits

- Gas or liquid service
- Better than 25 Ra finish in diaphragm cavity
- Stainless steel piston sensor
- 20 micron inlet filter
- Bubble-tight shutoff

DL-59 Series

To Order, contact your local Distributor Link below:
www.goreg.com/distributor/index.htm

Verify that your chosen part number is valid using the GO Wizards at
www.goreg.com/products/matrix/index.htm

How to Order

Standard items in bold.

DL59 – 1 A A 1 H 9 0 1 5 3 A

BODY MATERIAL

- 1** 316L stainless steel
- 2 Brass
- 4 MONEL®

PORT CONFIGURATIONS

- A** Standard
- For more port configurations, see page 9.

PROCESS PORT TYPES

(GAUGE PORT TYPE, IF SPECIFIED)

- 5** 1/2" FNPT (1/4" FNPT gauge ports)
- A** 3/4" FNPT (1/4" FNPT gauge ports)

SURFACE FINISH OF DIAPHRAGM CAVITY

- 1** < 25 Ra

SEAT MATERIAL

- H** PCTFE
- I** PTFE

OPTIONS

- A** EB33 (oxygen cleaning)
- B** EB5 cleaning
- D** Helium leak test
- E** Pressure test certificate
- F** Certificate of Conformity
- G** CMTR

DOME STYLE

- 3** Stainless steel, standard
- 4** Captured vent, stainless steel

PISTON MATERIAL

- 5** Stainless steel
- B** MONEL®

PISTON TYPE

- 1** Non-self-relieving
- 3** Self-relieving

DOME RATIO

- 0** 11:1
- 1** 43:1
- 2** 56:1
- 3** 76:1
- 4** 108:1
- 5** 122:1
- 6** 172:1
- 7** 20:1

FLOW COEFFICIENT (Cv)

- 9** 1.2

For flow curve charts, visit <http://www.goreg.com>.

NOTE: Contact the factory for any additional requirements.

Maximum Temperature & Operating Inlet Pressures

SEAT MATERIAL	MAXIMUM TEMPERATURE	@	MAXIMUM OPERATING INLET PRESSURE
PCTFE	175° F (80° C)	@	4000 psig (276 bar)
PTFE	150° F (66° C)	@	1000 psig (69 bar)

Outline and Mounting Dimensions

Weight = 8.4 lbs (3.8kg)

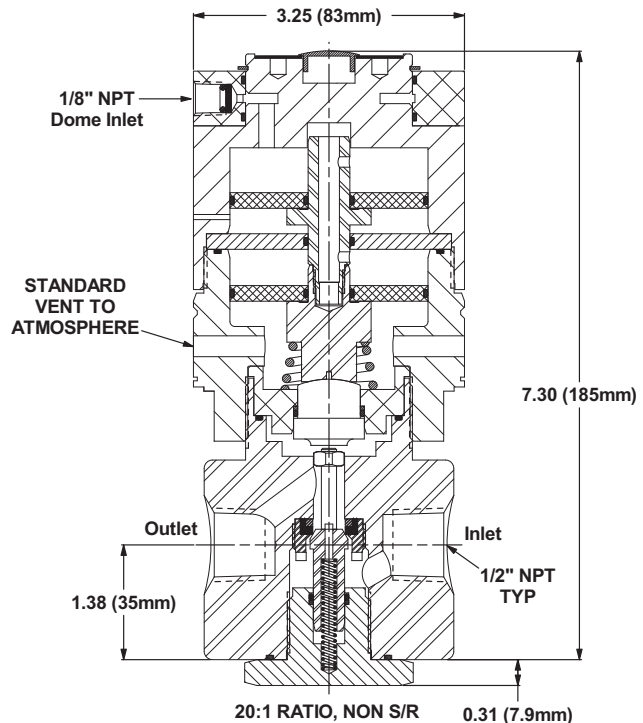

MONEL® is a registered trademark of Special Metals Corporation.
 Kel-F® is a registered trademark of 3M Company.

Porting Configurations for Dome-loaded Pressure Regulators

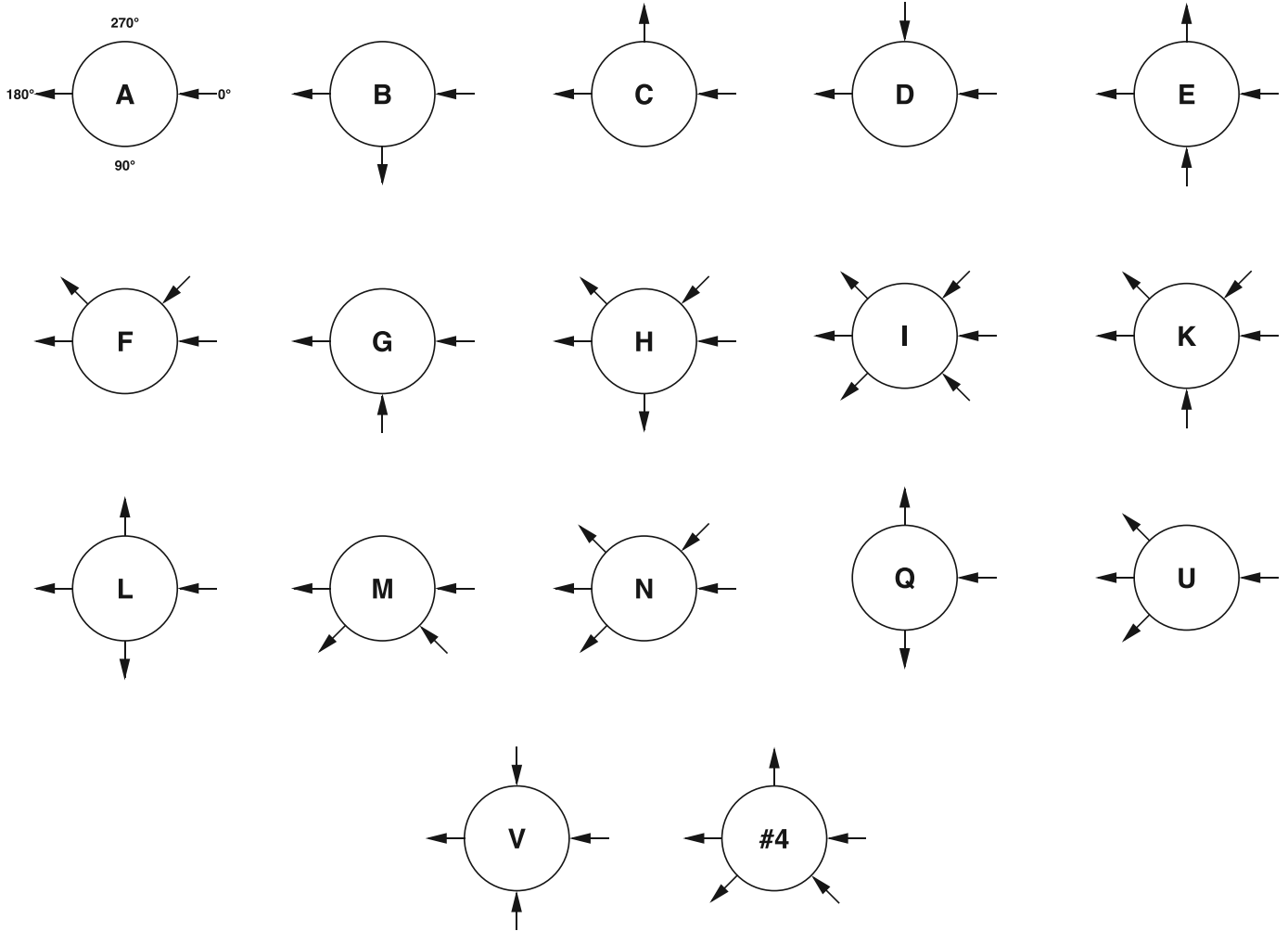

LOCATION OF PORTS FROM
TOP VIEW

GO REGULATOR, INC.

The Small Bore Instrumentation Specialists



We specialize in small bore instrumentation products up to 2" that deliver benchmark performance quality & safety; provide the broadest array of superior alloy offerings in the market; decades of proven success in a wide range of industries; a roster of "who's who" customers & projects globally; original "Best Solution" engineering & designs; and are focused on continuous improvement in all aspects of our business.

Proudly Distributed By:



CRANE INSTRUMENTATION &
SAMPLING Inc.
405 Centura Ct.
Spartanburg, SC 29305, USA
Tel: 1-864-574-7966
PO Box 4866, Spartanburg, SC
29305-4866 USA

Crane Co., and its subsidiaries cannot accept responsibility for possible errors in catalogues, brochures, other printed materials, and website information. Crane Co. reserves the right to alter its products without notice, including products already on order provided that such alteration can be made without changes being necessary in specifications already agreed. All trademarks in this material are the property of the Crane Co. or its subsidiaries. The Crane and Crane brands logotype (CENTER LINE®, COMPAC-NOZ®, CRANE®, DEPA® & ELRO®, DOPAK®, DUO-CHEK®, FLOWSEAL®, GYROLOK®, GO REGULATOR®, HOKE®, JENKINS®, KROMBACH®, NOZ-CHEK®, PACIFIC VALVES®, RESISTOFLEX®, REVO®, SAUNDERS®, STOCKHAM®, TEXAS SAMPLING®, TRIANGLE®, UNI-CHEK®, VALVES®, WTA®, and XOMOX®) are registered trademarks of Crane Co. All rights reserved.