

## MV-2 Series

Miniature Vaporizing Pressure Regulator

### Introduction

The MV-2 Series Miniature Vaporizing Regulator is one of the smallest envelopes in the industry. Weighing in at a scant 0.86 pounds, the MV-2 is designed to supply heat to samples entering instrumentation systems where space is at a premium and quality cannot be compromised. It can be used to preheat liquids, to prevent condensation of gases or to vaporize liquids prior to gas analysis.

The pressure control section of the MV-2 is patterned after the time-tested design of our CPR-1 and provides the same excellent outlet pressure stability. The heating plate utilizes GO Regulator's unique heating element and incorporates an optional Thermal Cutout Device (TCO). This device prevents any exposed surface of the unit from exceeding 200° C under normal or fault conditions and is exclusive to GO Regulator's line of electrically heated vaporizing regulators. Offered in both 12 VDC and 24 VDC, the MV-2 Series offers the utmost in unequalled system safety and performance.

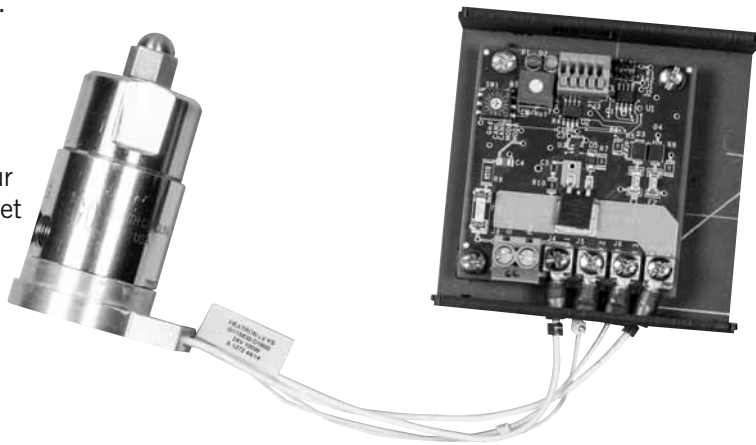

pressure regulators

### Typical Applications

#### Analytical process sample conditioning systems:

- Petrochemical refineries
- Chemical production facilities
- Pilot plants (chemical & petrochemical)
- Portable low voltage analyzers

### Technical Data

CONSTRUCTION	316L stainless steel
OUTLET PRESSURES	0-10, 0-25, 0-50, 0-100, 0-250, and 0-500 psig
OPERATING TEMPERATURE	up to 380° F (193° C)
HEATING CAPACITY RANGES (IN WATTS)	40 and 100

### Features & Benefits

- Electro polished body with better than 25 Ra finish in diaphragm cavity for an optimal sealing surface
- Bubble-tight shutoff
- Unique *Spiro-Wind* heating element provides exceptionally even heating
- Available in 12 VDC and 24 VDC
- Optional TCO heating cartridge

# MV-2 Series

To Order, contact your local Distributor Link below:  
[www.goreg.com/distributor/index.htm](http://www.goreg.com/distributor/index.htm)

Verify that your chosen part number is valid using the GO Wizards at  
[www.goreg.com/products/matrix/index.htm](http://www.goreg.com/products/matrix/index.htm)

## How to Order

Standard items in bold

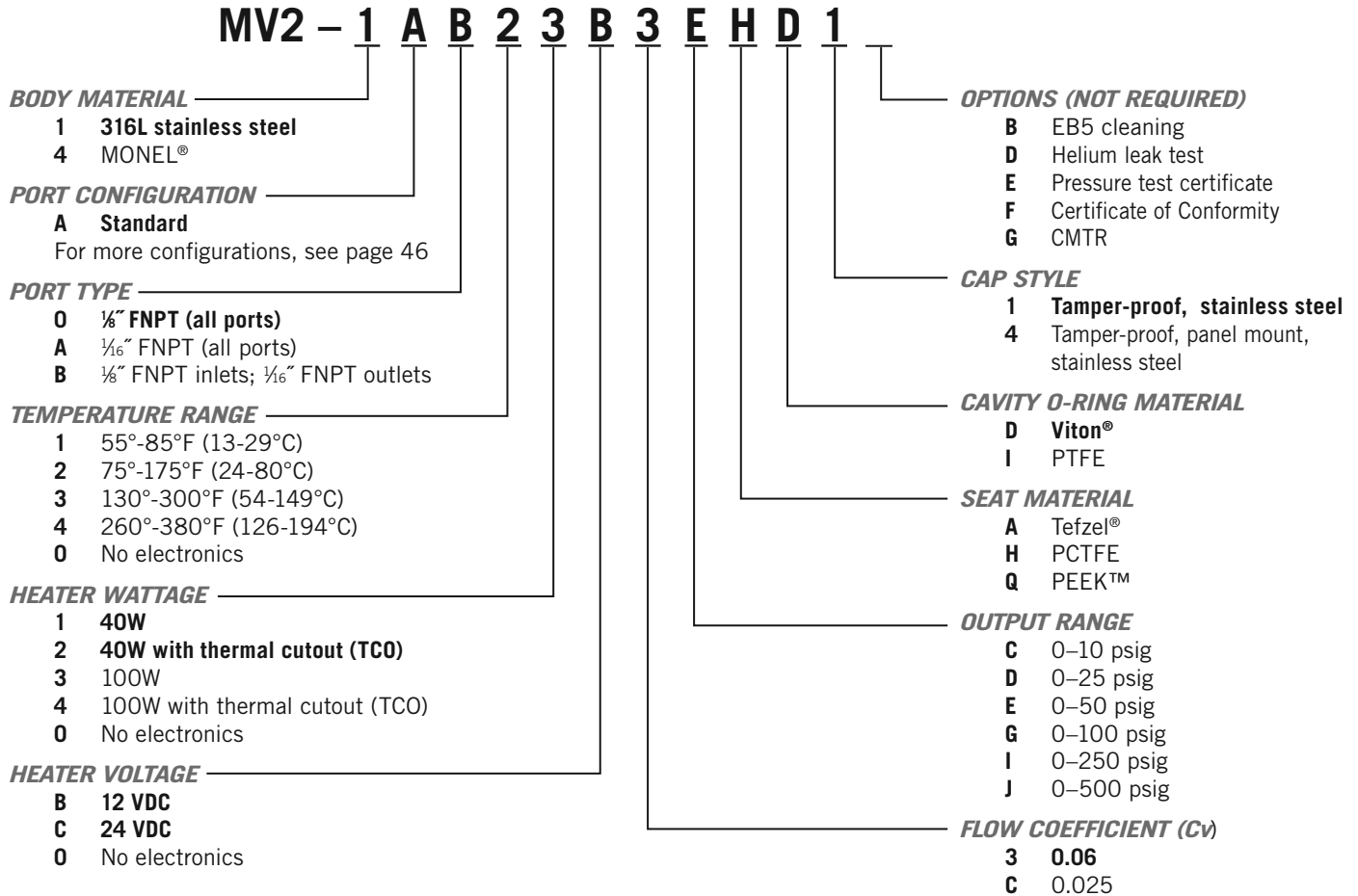

*NOTE: Contact the factory for any additional requirements.*

## Maximum Temperature & Operating Inlet Pressures

SEAT MATERIAL	MAXIMUM TEMPERATURE	@	MAXIMUM OPERATING INLET PRESSURE
Tefzel® & PCTFE	Up to 175° F (80° C)	@	3600 psig (24.82 MPa)
	176° F to 300° F (80° C to 148° C)	@	1000 psig (6.90 MPa)
	301° F to 380° F (148° C to 193° C)	@	400 psig (2.76 MPa)
PEEK™	Up to 380° F (193° C)	@	3600 psig (24.82 MPa)

# MV-2 Series

## Outline and Mounting Dimensions

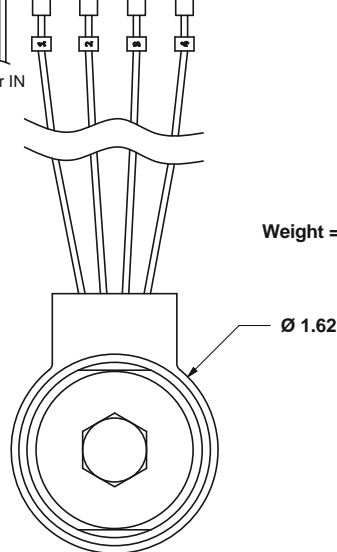
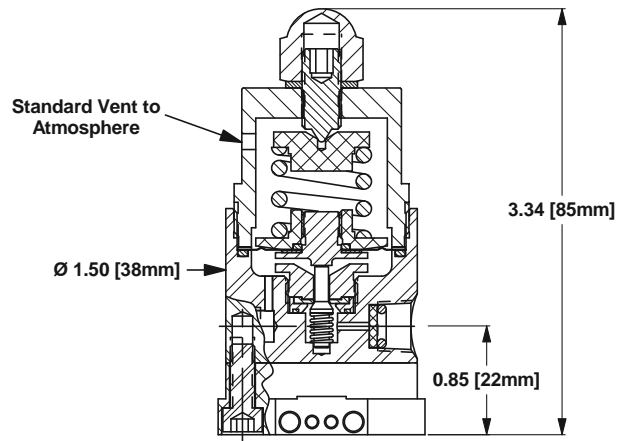
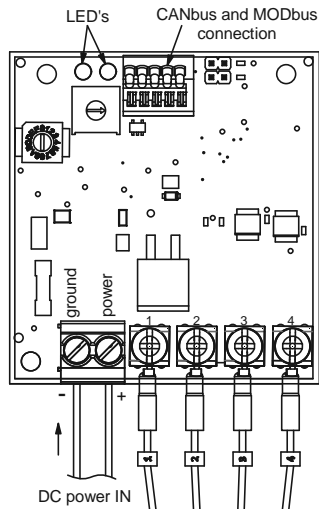
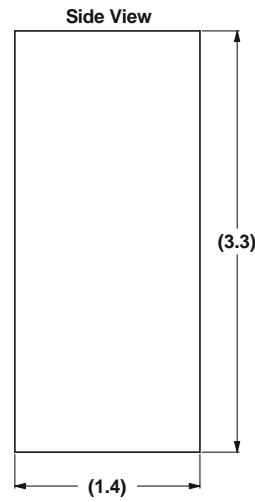
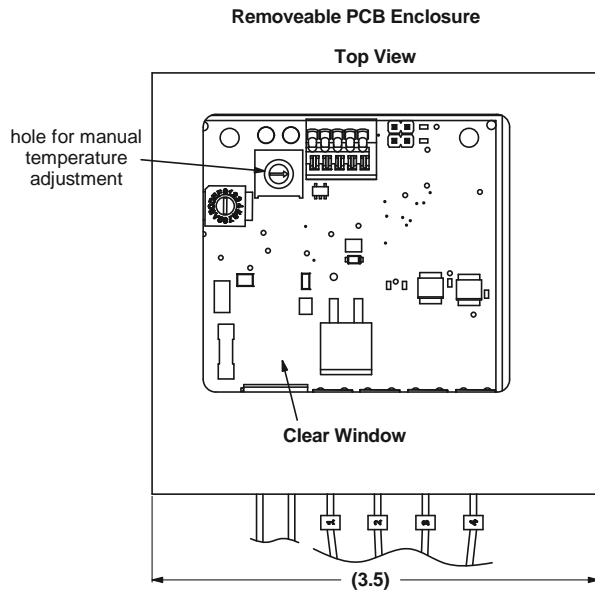

Weight = 0.86 lbs (.39 kg)

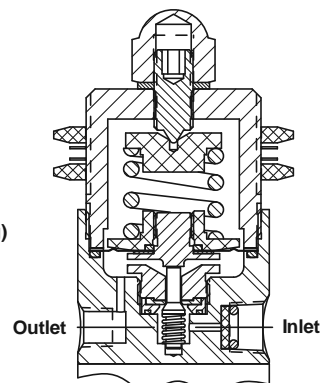

Panel Mount option requires 1.39 (35.3mm) minimum diameter panel cut out