

SPR Series

Subatmospheric Pressure Regulator



The SPR Series Subatmospheric Pressure Regulator is designed for the introduction of a low vapor pressure reactive or purge gas into a subatmospheric process. The large diameter diaphragm provides optimum sensitivity for subatmospheric or positive pressure control.

Standard features allow service in many varied applications including corrosive fluids and, with the optional features available, the user can tailor this regulator to applications ranging from semiconductor processing to analytical instrumentation.

Features & Specifications

- Subatmospheric or positive pressure control
- 20 micron inlet filter
- 316L stainless steel or INCONEL® construction
- Large stainless steel diaphragm with PTFE lining for optimal pressure control
- Inlet pressure range from 15–160 psia (0–145 psig)
- Adjustable outlet pressure range of 1–30 psia (27.88 in. H₂O = 15.3 psig)
- Cv flow coefficient of 0.2
- Bubble-tight shutoff
- Operating temperatures -40° F to +250° F (-40° C to +121° C)
- Inlet/outlet connections ¼" FNPT

Options

- Class 100 assembly
- Extra ports
- Panel mount (requires 1⅜" mounting hole)
- Pressure gauges

pressure regulators

How to Order

SPR –

BODY MATERIAL

- 1 316L stainless steel, stainless steel diaphragm
- 2 Brass, stainless steel diaphragm
- 4 MONEL®, INCONEL® diaphragm
- 6 HASTELLOY® C, INCONEL® diaphragm
- C SS 316L, INCONEL® diaphragm

PORT CONFIGURATION

- A Standard
- For more port configurations, see page 33.

PROCESS PORT TYPES

(GAUGE PORT TYPES, IF SPECIFIED)

- 1 ¼" FNPT (¼" FNPT gauge ports)
- 4 ⅜" FNPT (¼" FNPT gauge ports)

SURFACE FINISH OF DIAPHRAGM CAVITY

- 1 < 25 Ra, standard

SEAT MATERIAL

- A Tefzel®
- D Viton®
- K Kalrez®

FLOW COEFFICIENT (Cv)

- 5 0.2
- C 0.025
- H 0.5

OUTLET RANGE

- A 0–30 psia

OPTIONS

- A EB33
- B EB5
- D Helium leak test
- E Pressure test certificate
- F Certificate of Conformity
- G CMTR

CAP ASSEMBLY

- 1 Standard, stainless steel
- 2 T-handle, stainless steel
- 3 T-handle, panel mount, stainless steel
- 4 Panel mount, stainless steel
- 7 Captured vent, stainless steel
- 8 Tamper-proof, stainless steel
- 9 Fine adjust, ½" panel mount, stainless steel
- 0 Fine adjust, 1⅜" panel mount, stainless steel
- C Captured vent, panel mount, stainless steel
- E Tamper-proof, panel mount, stainless steel

DIAPHRAGM FACING/BACKING

- 1 PTFE/metal backing, standard
- 2 PTFE/Viton®
- 5 Viton®/metal backing
- 6 Tefzel® ring/metal backing

DIAPHRAGM TYPE

- 1 Standard

NOTE: Contact the factory for any additional requirements.

Maximum Temperature & Operating Inlet Pressures

SEAT MATERIAL	MAXIMUM TEMPERATURE*	@	MAXIMUM OPERATING INLET PRESSURE
Tefzel®	150° F (66° C)	@	145 psig (1000 kPa)
Viton®	250° F (121° C)	@	145 psig (1000 kPa)
Kalrez®	250° F (121° C)	@	145 psig (1000 kPa)

* Temperatures in excess of 175° F (80° C) require a metal knob or the tamper-proof option.

Outline and Mounting Dimensions

Weight = 3.2 lbs (1.45kg)

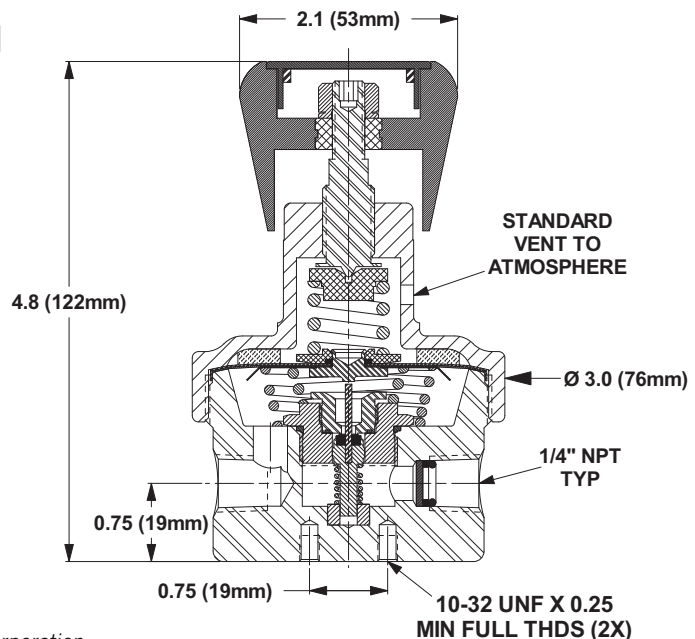

Tefzel® is a registered trademark of the DuPont Company.
 INCONEL® and MONEL® are registered trademarks of Special Metals Corporation.
 HASTELLOY® is a registered trademark of Haynes International, Inc.
 Kalrez® and Viton® are registered trademarks of DuPont Dow Elastomers.